



CHANCE RIDES MANUFACTURING, INC.
4200 Walker
Wichita, KS 67277-2328
U.S.A.
 Phone: 1-316-942-7411 • FAX: 1-316-942-2012
Website: www.rides.com
E-mail: rides@rides.com

Bulletin No: B407CRM155-0
 Release Date: April 3, 2008
 Effective Date: April 3, 2008
 Supersedes: N / A
 Completion Date: June 3, 2008
 Page: 1 of 3

SERVICE BULLETIN

Ride Manufacturer: CHANCERIDES, INC.
 CHANCERIDES MANUFACTURING, INC.

Affected Production Dates: June, 1994 and after

Ride Name: PHARAOH'S FURY

Affected Serial Nos.: 407-00294 and on

Model No.: 407

Abstract of Issue:

Lap Bar Mounting Bolt Installation and Inspection

Reason For Release:

The lap bar mount on the above noted PHARAOH'S FURY amusement ride is secured to the pivot area with a capscrew on each side. Chance Rides Manufacturing, Inc. has received reports of these capscrews coming loose. If one or both of these screws came out, the lap bar could come loose and result in potential injury to the passengers and/or bystanders.

This service bulletin describes the procedure to install and inspect these capscrews to ensure that the capscrews remain tight and the lap bar remains secure.

Action to be Taken:

All owner/operators of the above noted amusement rides must replace the fasteners on all lap bars within 60 days of the release date of this bulletin. Use the procedure described on the following pages of this bulletin. These fasteners can be procured locally or from CHANCE RIDES MANUFACTURING, INC.

<u>Chance Part Number</u>	<u>Description</u>	<u>Quantity</u>
60768000	HEX HEAD CAPSCREW (3/8-16 x 2-3/4") Grade 5	20 required
28538803	LOCKING WASHER SET (Nord-Lock NL3/8")	20 required

To ensure that these capscrews do not become loose, they must be inspected monthly as described in this bulletin.

Observe all safety information contained in the manufacturer's manuals. Make available this bulletin and all related technical information to personnel using the equipment.

Chance Rides Manufacturing, Inc. issues notifications for the benefit of owners of amusement rides manufactured by Chance Rides Manufacturing, Inc. As a service to the industry, and in the interest of employee and public safety, Chance Rides Manufacturing, Inc. also issues notifications for the benefit of owners of amusement ride equipment for which the manufacturer no longer exists, such as the Allan Herschell Company, Chance Manufacturing Co., Inc., Chance Rides, Inc., etc. In doing so, Chance Rides Manufacturing, Inc. does not assume liability for losses associated with amusement ride equipment built by manufacturers other than Chance Rides Manufacturing, Inc.



CHANCE RIDES MANUFACTURING, INC.
4200 Walker
Wichita, KS 67277-2328
U.S.A.
Phone: 1-316-942-7411 • FAX: 1-316-942-2012
Website: www.rides.com
E-mail: rides@rides.com

Bulletin No:	B407CRM155-0
Release Date:	April 3, 2008
Effective Date:	April 3, 2008
Supersedes:	N / A
Completion Date:	June 3, 2008
Page:	2 of 3

Ride Manufacturer: CHANCERIDES, INC. Affected Production Dates: June, 1994 and after
CHANCERIDESMANUFACTURING, INC.

Ride Name: PHARAOH'S FURY Affected Serial Nos.: 407-00294 and on

Model No.: 407

Detail of Issue (continued):

Capscrew Replacement

1. Remove the existing capscrews and split lock washers from both ends of the lap bar mount. Discard these fasteners.
2. Remove the lap bar mount from the sockets and thoroughly clean the internal threads
3. Inspect the threads in both ends of the lap bar mount. Look for corrosion, stripped threads, wear or other damage. If damage is found, contact the Customer Service Department at Chance Rides Manufacturing, Inc.
4. Coat the threads on the new capscrews with anti-seize compound.
5. Install the lap bar mount using new capscrews and locking washer set, which consists of two special locking washers. Refer to the detail on the following page for installation of the locking washer set.

IMPORTANT: *The special locking washer set can be re-used up to five times, after which it must be discarded and replaced with a new set.*

6. Tighten the capscrew to 19 to 24 ft-lbs.
7. Repeat this process on all lap bars.

Monthly Capscrew Inspection

Using a torque wrench, check for proper torque of all 20 capscrews. The torque value for checking these capscrews must be 19 to 24 ft-lbs. The capscrew should not turn.

If any capscrew is found to be loose, remove it and replace it with a new capscrew using the procedure described above.



CHANCE RIDES MANUFACTURING, INC.
4200 Walker
Wichita, KS 67277-2328
U.S.A.
Phone: 1-316-942-7411 • FAX: 1-316-942-2012
Website: www.rides.com
E-mail: rides@rides.com

Bulletin No:	B407CRM155-0
Release Date:	April 3, 2008
Effective Date:	April 3, 2008
Supersedes:	N / A
Completion Date:	June 3, 2008
Page:	3 of 3

Ride Manufacturer: CHANCERIDES, INC.
CHANCERIDESMANUFACTURING, INC.

Affected Production Dates: June, 1994 and after

Ride Name: PHARAOH'S FURY

Affected Serial Nos.: 407-00294 and on

Model No.: 407

Detail of Issue (continued):

Installation Detail of LOCKING WASHER SET

These washers must be installed in pairs. Make sure the coarse serrations of the two washers are mated with each other as shown. The fine serrations must be against the capscrew head and the mounting base.

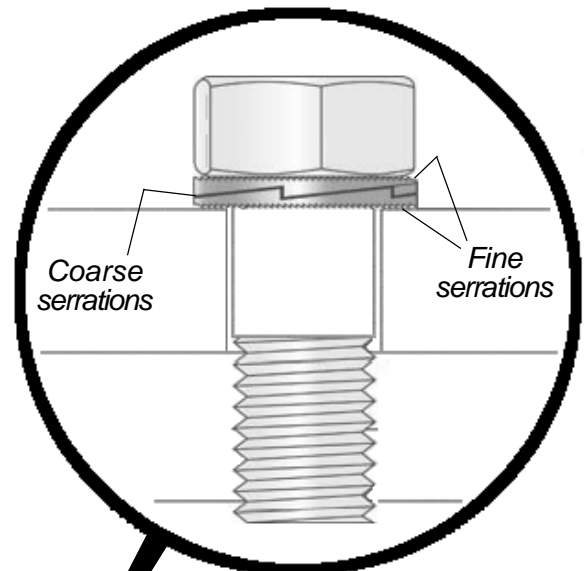

Discard existing capscrew. Replace with new Hex Head Capscrew - 3/8-16 x 2-3/4" (part number 60768000) Tighten to 19 to 24 ft-lbs.

Discard existing split lockwasher. Replace with LOCKING WASHER SET, which consists of two special washers, installed exactly as shown in the detail (part number 228538803)

Inspect threads for damage inside lap bar mount

