



CHANCE RIDES MANUFACTURING, INC.
4200 Walker
Wichita, KS 67277-2328
U.S.A.
 Phone: 1-316-942-7411 • FAX: 1-316-942-2012
 Website: www.rides.com
 E-mail: rides@rides.com

Bulletin No:	B408CRM168-0
Release Date:	August 10, 2010
Effective Date:	August 10, 2010
Supersedes:	N/A
Completion Date:	See Text
Page:	1 of 3

SERVICE BULLETIN

Ride Manufacturer: CHANCE RIDES, INC. Affected Production Dates: All

Ride Name: CHAOS Affected Serial Nos.: All

Model No.: 408

Abstract of Issue:
 Tilt Cylinder Inspection

Reason For Release:

Chance Rides Manufacturing, Inc. has become aware that cracks can develop in the hub tilt cylinders on the above noted CHAOS amusement rides. This condition can result in injury to passengers.

Action to be Taken:

All owners of the above noted CHAOS amusement rides are required to inspect the tilt cylinders as described in this bulletin. The inspection must be completed within 30 days upon receipt of this bulletin and annually thereafter.

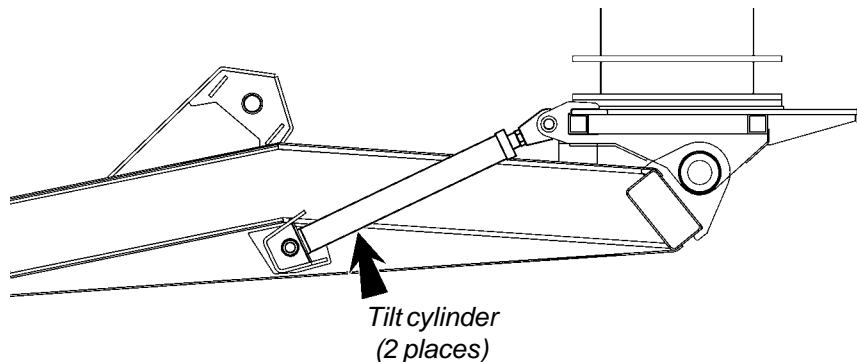

All work must be performed by qualified personnel, capable of understanding the function of the parts and their proper installation. Use only those components authorized, specified or provided by Chance Rides Manufacturing, Inc. All applicable OSHA safety standards and safe industry practices must be observed. Observe all safety information contained in the manufacturer's manuals. Make available this bulletin and all related technical information to personnel using the equipment.

Chance Rides Manufacturing, Inc. issues notifications for the benefit of owners of amusement rides manufactured by Chance Rides Manufacturing, Inc. As a service to the industry, and in the interest of employee and public safety, Chance Rides Manufacturing, Inc. also issues notifications for the benefit of owners of amusement ride equipment for which the manufacturer no longer exists, such as the Allan Herschell Company, Chance Manufacturing Co., Inc., Chance Rides, Inc., etc. In doing so, Chance Rides Manufacturing, Inc. does not assume liability for losses associated with amusement ride equipment built by manufacturers other than Chance Rides Manufacturing, Inc.



CHANCE RIDES MANUFACTURING, INC.
4200 Walker
Wichita, KS 67277-2328
U.S.A.
Phone: 1-316-942-7411 • FAX: 1-316-942-2012
Website: www.rides.com
E-mail: rides@rides.com

Bulletin No:	B408CRM168-0
Release Date:	August 10, 2010
Effective Date:	August 10, 2010
Supersedes:	N/A
Completion Date:	See Text
Page:	2 of 3

Ride Manufacturer: CHANCE RIDES, INC. Affected Production Dates: All

Ride Name: CHAOS Affected Serial Nos.: All

Model No.: 408

Detail of Issue

Tilt Cylinder Inspection Procedure

IMPORTANT: *The tilt cylinders must be removed from the ride for inspection. Secure the hub and use all appropriate precautions to prevent unintended tilting or other movement of the hub before removing the tilt cylinders.*

Magnetic particle inspection (MT) must be used to inspect the cylinders. The inspection must be performed by a certified Level II or Level III NDT inspector.

Inspect the areas shown in the detail on the following page. Look for indications in the steel barrel and the mounting ears. Check the welded joints for indications in the welds and the parent metal.

Magnetic Particle Inspection (MT) Procedure

1. Remove paint and contaminants from the area to be inspected.
2. Use dry powder and a magnetic yoke.
3. Position the yoke so that the longitudinal magnetic field cuts across the weld at a perpendicular angle.
4. After positioning the yoke, use the continuous method.
5. Inspect for discontinuities.
6. If any discontinuity is found, contact Chance Rides Manufacturing, Inc.



CHANCE RIDES MANUFACTURING, INC.
4200 Walker
Wichita, KS 67277-2328
U.S.A.
Phone: 1-316-942-7411 • FAX: 1-316-942-2012
Website: www.rides.com
E-mail: rides@rides.com

Bulletin No:	B408CRM168-0
Release Date:	August 10, 2010
Effective Date:	August 10, 2010
Supersedes:	N/A
Completion Date:	See Text
Page:	3 of 3

Ride Manufacturer: CHANCE RIDES, INC. Affected Production Dates: All

Ride Name: CHAOS Affected Serial Nos.: All

Model No.: 408

Detail of Issue (continued):

Use Magnetic Particle Inspection (MT) as specified to inspect the barrel end of each tilt cylinder. Look for indications in the steel barrel and the mounting ears.

Also, check the welded joints for indications in the welds and the parent metal in this area

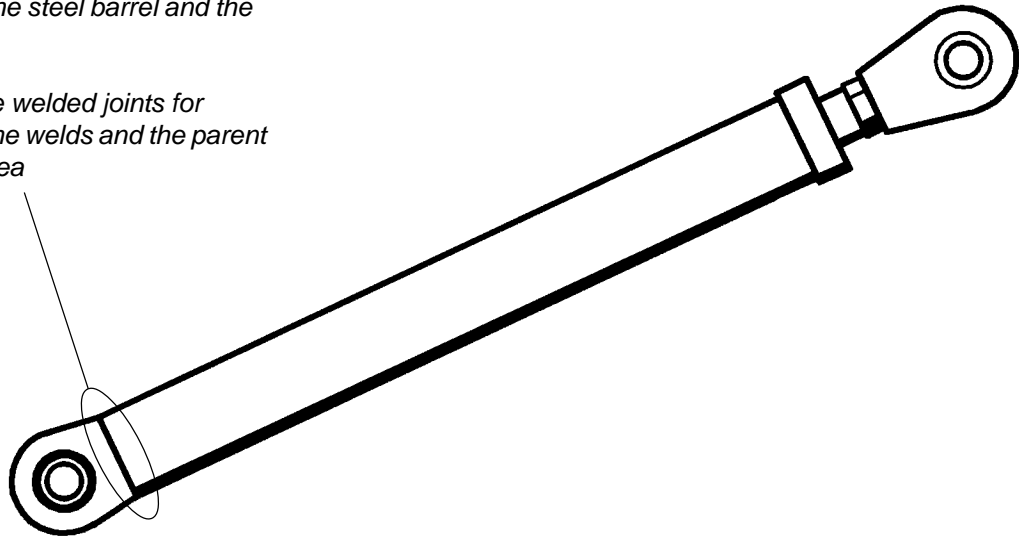

IF NO INDICATIONS ARE FOUND, operation of the ride can continue. The tilt cylinders must be inspected annually as described in this bulletin.

IF ANY INDICATIONS ARE FOUND, do not operate the ride. Contact the Customer Service Department at Chance Rides Manufacturing, Inc. immediately for instructions on the necessary repair procedure. **DO NOT ATTEMPT TO WELD OR OTHERWISE REPAIR THE CYLINDER UNLESS SPECIFICALLY INSTRUCTED BY CHANCE RIDES MANUFACTURING, INC.**

Perform this inspection within 30 days upon receipt of this bulletin and annually thereafter.