



ALLAN HERSCHELL

CHANCE
MANUFACTURING CO., INC.

124

Number: 6-29-76

Date:

Superceeds:

Number:

Date:

Service Information

Ride: YO YO RIDES 74-3300 THROUGH
76-3342

Subject: CYLINDER END CAP CHECK AND
REPLACEMENT

Due to a sweep lift cylinder end cap having blown out on a YO YO, we have had tests performed by an outside testing firm. The failure was determined to be due to an overloading of the hydraulic system. To prevent further incidents, maximum hydraulic pressure settings should not be exceeded and a new cylinder end cap installed. There is a hydraulic schematic for your ride attached to this bulletin. Rides 74-3300 through 75-3333 have had a temporary kit installed on the end cap which should serve through the remainder of the season. Rides 75-3333 through 76-3342 have been operating less than one season and should serve until the new design end cap can be installed at the end of this season.

New stronger design end caps will be available from the cylinder manufacturer for all rides through 76-3342 by mid-July. Make appointments for installation of these kits with Dick Chance as soon as possible. If you are in our area, installation is available at the factory. This installation will be much faster than road service, which is also available.

SEE REVERSE SIDE FOR DRAWING

Factory and General Office, 4219 Irving, Box 2397 Wichita, Kansas 67201

Area Code (316) 942-7411

Sales Office:

103 Ross Ave., Dallas, Texas 75202

Area Code (214) 742-3802

To insure safe operation until the new design end caps are installed, cylinder end caps on all rides should be checked weekly as follows:

Place a straight edge across the end cap as shown in drawing. Check in at least two positions, 90° apart. Try to insert a 1/16" feeler gauge under straight edge. If end cap shows more than 1/16" gap, notify factory at once.

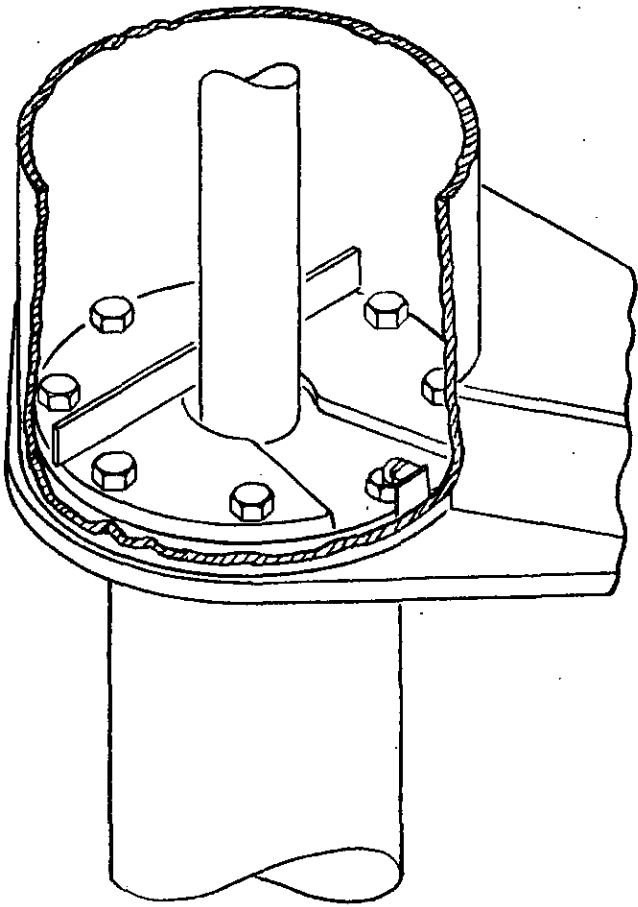

WITH TEMPORARY KIT

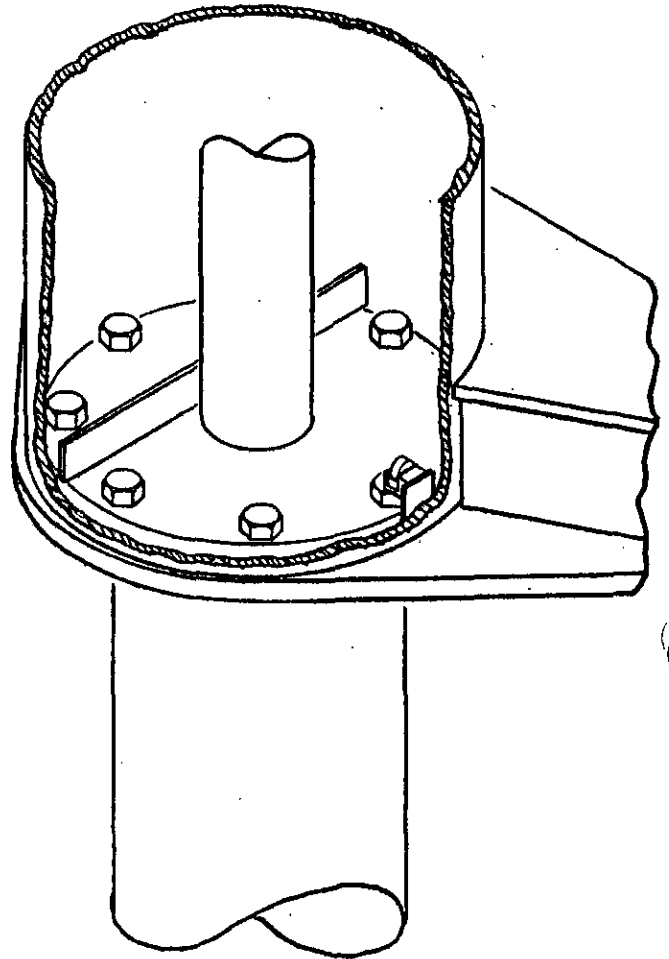

WITHOUT TEMPORARY KIT