



Number: B61-0265-0A

Date: 4-15-86

Supersedes: B61-0265-00
(2-20-85)

America's Largest Manufacturer of Amusement Rides

SERVICE BULLETIN

Effective Serial Numbers: All Units

Ride: YO YO

Subject: Chain and Seat Inspection

As a safety precaution, CHANCE MANUFACTURING CO., INC. recommends that the following inspection be performed on all YO YO amusement rides at every set-up or weekly, whichever occurs first.

The inspection must be performed by competent personnel, capable of understanding the function of the parts and their proper installation. A parts list is included for identification of parts and as a convenience for ordering any necessary parts.

Inspection Points

1. CHAIR HANGER - Inspect for damage or wear in the holes for the snap hook.
2. SNAP HOOK - Check the inside of the hook for damage or wear. The spring catch must operate freely and close the hook completely.
3. ADAPTER PLATES AND ATTACHING HARDWARE -

NOTE: Early production rides were equipped with either shackles or cold shuts to attach the chains to the snap hooks. Inspect these for damage or wear, and refer to Service Bulletin No. 94. If your ride is equipped with either shackles or cold shuts, go to Step 4.

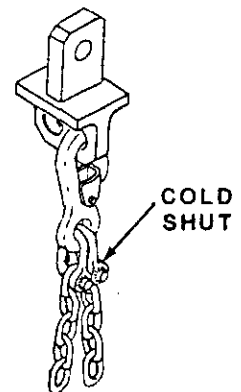
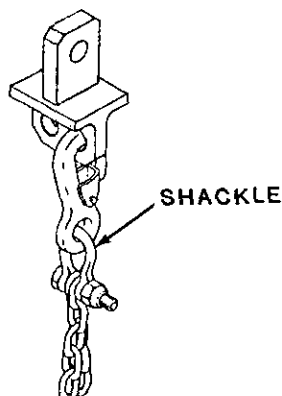
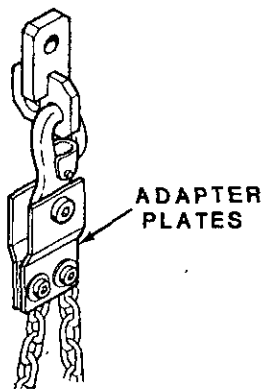

Check the position of the hardware which secures the chains and snap hooks to the adapter plates. The heads of the shoulder bolts must be to the inside of each chair hanger as shown. Contact of the threaded ends of the shoulder bolts can cause damage to the fasteners.

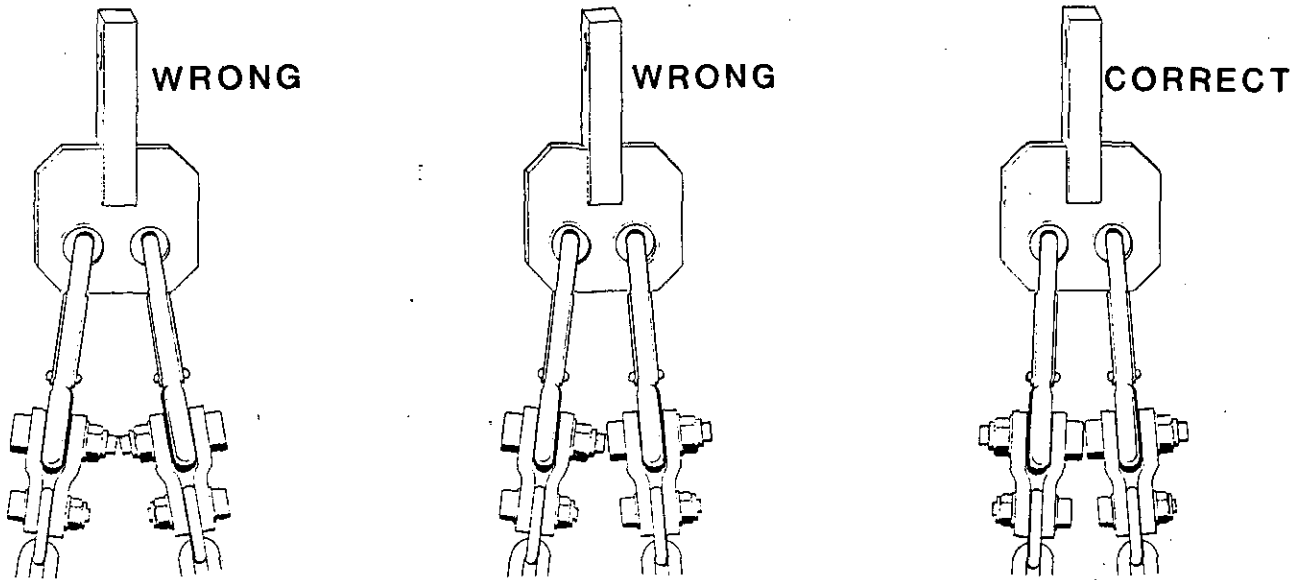

Torque the 1/2-inch shoulder bolts (3/8-16 thread) to 36 lb-ft. Torque the 3/8-inch shoulder bolts (5/16-18 thread) to 17 lb-ft. DO NOT SUBSTITUTE HARDWARE.

4. CHAINS - Carefully inspect all chains for wear, damage or broken welds on links. Measure chain wear on links near the seat as shown. The minimum acceptable dimension is 0.145 inch. If replacement is required, use only 3/16-inch proof coil chain. DO NOT SUBSTITUTE CHAINS. DO NOT SPLICE OR OTHERWISE ATTEMPT TO REPAIR CHAINS.

If end links are worn, up to three links can be removed to shorten all four chains by the same amount. ALL FOUR CHAINS FOR EACH SEAT MUST BE THE SAME LENGTH (13 ft. 5-3/8 in. minimum).

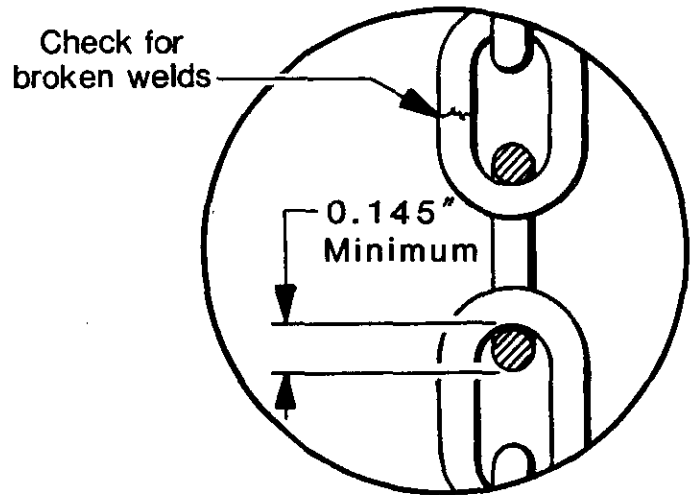

5. SEAT ATTACHMENT HARDWARE - Make sure that all bolts point out from seat. Torque the nuts to 13 lb-ft. DO NOT SUBSTITUTE HARDWARE.
6. SEAT AND SEAT FRAME - Check for cracks in the plastic seat. Inspect the seat frame for damage or wear in the area where the lap bar rests.
7. CHEST STRAP, CROTCH STRAP AND LAP BAR - All seats must be equipped with the complete passenger restraint system as shown. Replace any worn, damaged or missing parts.
8. OVERALL INSTALLATION OF CHAINS AND SEATS - All seats must be facing in the same direction - forward in relation to ride rotation. Each seat must be suspended from two chair hangers. DO NOT ATTACH BOTH SNAP HOOKS FOR A SINGLE SEAT TO THE SAME CHAIR HANGER. Snap hooks must be installed in the chair hangers toward the center of the ride as shown. Make sure the chains are not twisted.

If you have any questions or need replacement parts, contact the CHANCE CUSTOMER SERVICE DEPARTMENT.

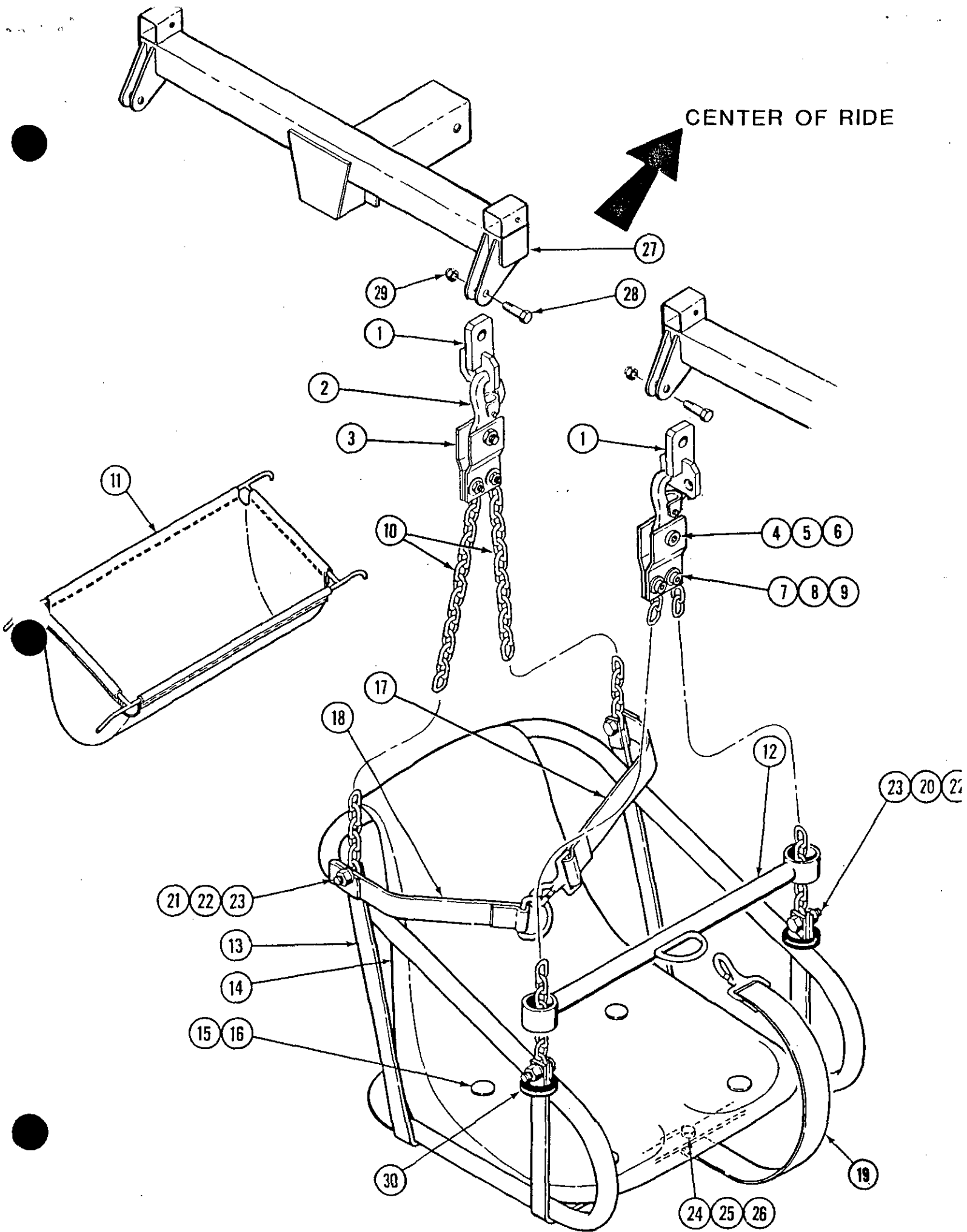

Parts List

Ref. No.	Part No.	Description	32 Seats Per Ride, Qty. Req'd. Per Seat .
1	361-32706	* Chair Hanger (376-209-001)	1
2	290-69296	Snap Hook	2
3	361-53843	**Adapter Plate (376-118-001)	4
4	690-12267	Shoulder Bolt - Socket Head (1/2 x 1, 3/8-16 Thd) ..	2
5	696-85310	Washer - Flat (3/8)	2
6	691-48046	Nut - Flexlock (3/8-16)	2
7	686-12232	Shoulder Bolt - Socket Head (3/8 x 1, 5/16-18 Thd) .	2
8	696-85304	Washer - Wrought (5/16)	2
9	691-48044	Nut - Flexlock (5/16-18)	2
10	290-15213	Chain (3/16 Proof Coil x 13 ft. 8 in. long)	4
11	361-15290	Chain Bag (376-914-001)	1
12	361-04043	Lap Bar Weldment (376-111-001)	1
13	361-29215	Seat Frame (376-110-001)	1
14	361-64993	Seat (376-113-001) Specify Color: Black, Red, Navy Blue or Sand	1
15	686-12219	Carriage Bolt (1/4-20 x 1-1/4)	4
16	691-47808	Lock Nut - Full Nylon Insert (1/4-20)	4
17	261-05443	Chest Strap (376-114-002)	1
18	261-05442	Chest Strap (376-114-001)	1
19	261-05443	Crotch Strap (376-114-002)	1
20	686-12232	Shoulder Bolt-Socket Head (3/8 x 1, 5/16-18 Thd) ...	2
21	686-12233	Shoulder Bolt-Socket Head (3/8 x 1-1/4, 5/16-18 Thd).	2
22	696-85308	Washer - Wrought (3/8)	8
23	691-48044	Nut - Flexlock (5/16-18)	4
24	686-07004	Bolt - Hex Head Capscrew (1/4-20 x 1)	1
25	696-85300	Washer - Wrought (1/4)	1
26	691-47808	Lock Nut - Full Nylon Insert (1/4-20)	1
27	361-04045	Tee Bar Weldment (376-213-001)	***
27	361-04047	Tee Bar Weldment With Ladder Hooks (376-213-009) ...	***
28	686-09526	Bolt - Hex Head Capscrew (3/4-10 x 3-1/4 Grade 5) ..	32/ride
29	691-47836	Lock Nut - Full Nylon Insert (3/4-10)	32/ride
30	261-85602	Cushion Ring	2/seat

* The chair hanger shown is interchangeable with the chair hangers originally equipped on early production rides.

** Early production rides were equipped with either shackles or cold shuts, which are no longer provided for this application. When replacing these parts, order items 3 through 9 in the quantities specified.

*** Portable rides require one Tee Bar With Hook (376-213-009) and fifteen Tee Bars (376-213-001). Park model rides require sixteen Tee Bars (376-213-001).