

Customer Support

Maurer Rides GmbH
Frankfurter Ring 193
80807 München

Service Bulletin 001/07

March 2007

Ride: Compact Spinning Coaster, SC 2000, SC 3000
Module: Locking system

With respect to the locking at the vehicles of the installations Compact Spinning Coaster and Spinning Coaster, we were approached by our customers, last year, with the information that the wear data contained in our operation and maintenance manual was insufficient regarding the elements at the vehicle locking, in particular the locking teeth and tooth segments.

Therefore, we have decided to provide you with more detailed and precise information on the above matter. By means of the new data you will see more clearly how the wear limits of the locking teeth and the tooth segments can be determined. Thus, you will get a better idea when it comes to deciding whether you still wish to use the installed parts or have them replaced.

Enclosed you will find the relevant passages in section no. 8.9.5 *Checking the Safety Bar* on pages 8-64 to 8-66.

Please be so kind as to attach these documents to the relevant section of your operation and maintenance manual.

Munich, 21th March 2007

Guido Bauerle
Manager Customer Support



8.9.4 Testing area

For in-depth vehicle testing and for setting the wheels and mechanics of the lower car assembly, the vehicle must be moved onto the testing area of the maintenance spur track. The testing area is equipped with the required gauges for position testing for the brake fins, anti roll back dog, chain hooks and drive beams.

For easily setting the side-wheels, the rails in the testing area are made a bit wider by the required play in the side-wheels.

8.9.5 Checking the safety bar

Visual check of the locking mechanism

- ▶ Push vehicle out, move it to the testing area and fix the rear wheel axle with the stop
- ▶ Remove the covers in the footwell of the vehicle and take a sitting position in the vehicle



A second person must participate in this test to manually unlock the safety bar.

- ▶ Close the safety bar until the grabber teeth (1) rest solidly and test the functionality with all of your arm strength.
- ▶ Slowly close the safety bar further and observe the resting movements of the ratchet mechanism (2).
- ▶ Press the safety bar away from your body with all of your strength and observe the locking mechanism at the same time. The ratchet mechanism should not move.
- ▶ Repeat this procedure for all teeth in the locking mechanism, on all safety bars and on all vehicles.

Both ratchets of every safety bar alternate when coming to rest in alternation.

- ▶ Check that the teeth are not contaminated with layers of grease. Clean any grease that is stuck to the mechanism.

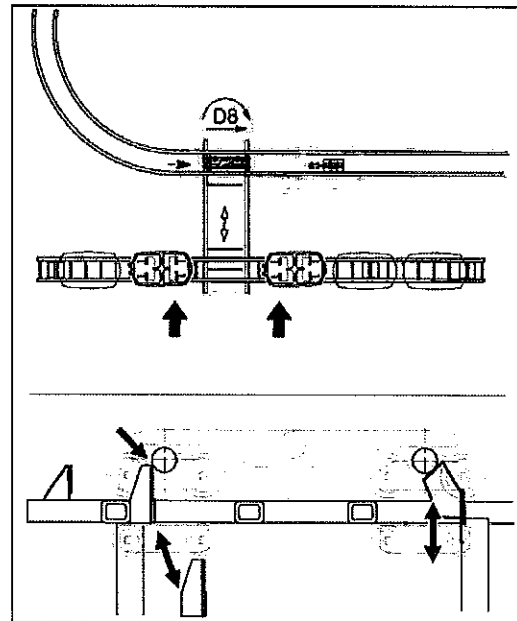

Testing area on maintenance spur track

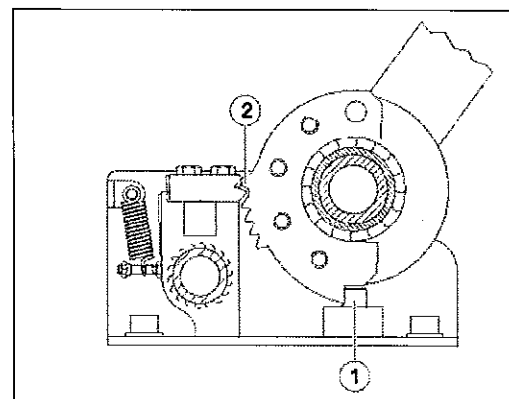

Safety bar ratchet

Shut down any vehicles with damaged latches and inform the manufacturer of the procedures for approving further procedures.

Checking the ratchet for wear

- ▶ Remove the ratchet.
- ▶ Put the ratchet on the workbench and push the tooth against the vertical, flat stop plate.
- ▶ Determine wear X with the feeler gauge.

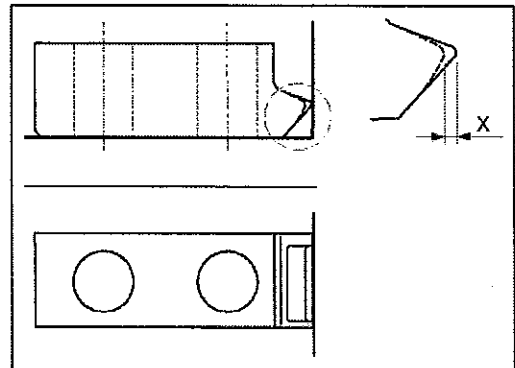

Ratchet wear check

Checking the toothed plate for wear

- ▶ Remove the toothed plate.
- ▶ Align the toothed plate evenly over an unused toothed plate and bolt the two together.
- ▶ Press the measuring plate against the even tooth edge and hold there.
- ▶ Determine the wear Y on all teeth with the feeler gauge.

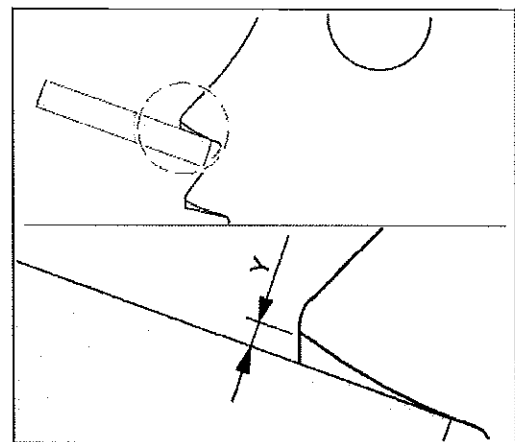

Toothed plate wear test

Installing the toothed plate and the ratchet

- ▶ Combine the ratchet and the toothed plate according to the wear, see following table.
- ▶ Replace toothed plates and ratchets with more than 0.7 mm wear

Combination	Ratchet, max. wear X	Toothed plate, max. wear Y
A	0.5 mm	0.7 mm
B	0.7 mm	0.5 mm

- Combination A: Combine ratchet with wear up to 0.5 mm and toothed plates with wear to 0.7 mm.
- Combination B: Combine ratchet with wear up to 0.7 mm and toothed plates with wear to 0.5 mm.
- ▶ Install the ratchet, torque: 35 Nm, Secure with Loctite 243.
- ▶ Install the toothed plate, torque: 70 Nm, Secure with Loctite 243.



Checking the locking spring

- ▶ Check the spring tension with the bar open by lifting the ratchet latches from the toothed plate. A clearly audible latching of the ratchet on the toothed plate is an indication of a good spring.

Replace broken, damaged and missing springs.

- ▶ Repeat tests on the three remaining safety bars of the vehicle.

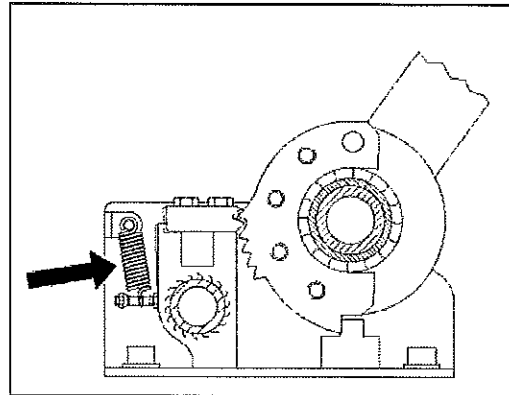

Spring on the safety bar

Checking the unlatching system

- ▶ Check the protrusion of the lever (1) over the frame beam (2) of the upper car assembly with the distance gauge. Set value: 3 mm.



WARNING

The vehicle and the system can be damaged if the lever is protruding more than 3 mm down over the frame beam of the upper car assembly.

- ▶ Set the set value of 3 mm on the upper lever with the set screw (3).
- ▶ Check the space between the pressure plate (1) and the tappet (4) with the feeler gauge. Set value: 3 mm.
- ▶ Set the set value of 3 mm on the lower lever with the set screw (5).
- ▶ Check the tension of the nuts on the set screws; tighten loose nuts.

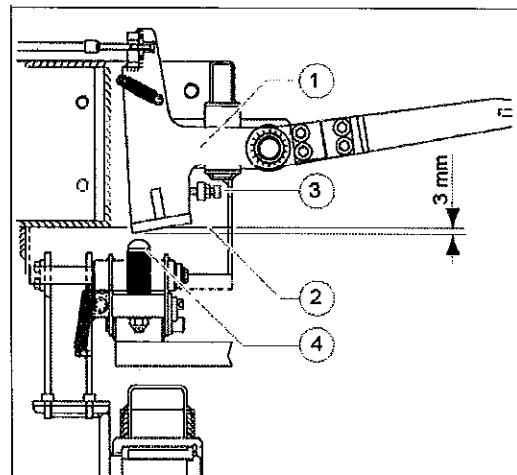

Unlatching, lever protrusion

Checking the pressure plate fastening

- ▶ Shake the pressure plate (1).
- ▶ Secure the bolts with Loctite 243 and tighten to 25 Nm if the pressure plate is loose.

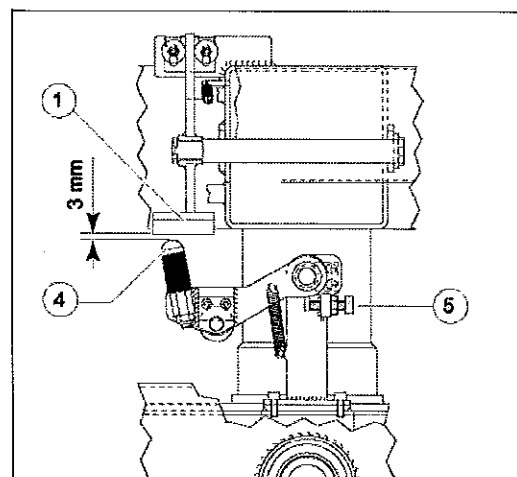

Unlatching, space between lever and tappet