



Issuing Entity:
 Vekoma Rides Parts & Services B.V.
 Schaapweg 18
 6063 BA VLODROP
 The Netherlands

Bulletin No.: 1-SB-003-011106
 Release Date:
 Effective Date: Immediately
 Supersedes: N.A.
 Completion Date: N.A.

Service Bulletin

Original Ride Manufacturer: Vekoma Manufacturing B.V. Vekoma International B.V.	Affected Production Dates: All rides installed before 24-08-2001
Ride Name: SFC and SLC	Affected Serial Nos: table 1
Model No: N.A.	392-1

<p>Abstract of issue:</p> <p>Securing Suspended Vekoma L2 / L3 Brake shoe against falling down caused by a single point failure</p>
<p>Reason for release:</p> <p>Precautionary measures to prevent a brake shoe falling down from a suspended brake.</p>
<p>Action to be taken:</p> <p>Carry out this modification.</p>

IB-nr.	Name	Project number
36501	SFC	20121
36502	SFC	20160

32001	SLC	92604
32002	SLC	93144
32003	SLC	93137
32004	SLC	94103
32005	SLC	94117
32007	SLC	94119
32008	SLC	94124
32009	SLC	94133
32010	SLC	94136

Vekoma Rides Parts & Services B.V. issues notifications for the benefit of owners of amusement rides manufactured by Vekoma Rides Manufacturing B.V. as a service to the industry, and in the interest of employee and public safety. Vekoma Rides Parts & Services B.V. also issue notifications for the benefit of owners of amusement ride equipment for which the manufacturer no longer exists, such as Vekoma International B.V. and Vekoma Manufacturing B.V. In doing so, Vekoma Rides Parts & Services B.V. and Vekoma Rides Manufacturing B.V., including affiliated companies, agents and employees make no warranties and assume no responsibility for any misapplication or misinterpretation of the information provided, ride down time, consequential damages injuries, causes of action, claims, demands and expenses (including legal fees), of any kind or nature, arising directly or indirectly, in whole or in part, from or out of this notification or associated with amusement ride equipment built by manufacturers other than Vekoma Rides Manufacturing B.V.

IB-nr.	Name	Project number
32011	SLC	95107
32012	SLC	96398
32013	SLC	95164
32014	SLC	95170
32015	SLC	96350
32016	SLC	96362
32017	SLC	96344
32018	SLC	96356
32019	SLC	96289
32020	SLC	97119
32021	SLC	97103
32022	SLC	97163
32023	SLC	97330
32024	SLC	97154
32025	SLC	97197
32026	SLC	97332
32027	SLC	97331
32028	SLC	97123
32029	SLC	98130
32030	SLC	99262
32031	SLC	98182
32032	SLC	99272

table 1 Affected serial Nos.

Vekoma Rides Parts & Services B.V. issues notifications for the benefit of owners of amusement rides manufactured by Vekoma Rides Manufacturing B.V. as a service to the industry, and in the interest of employee and public safety. Vekoma Rides Parts & Services B.V. also issue notifications for the benefit of owners of amusement ride equipment for which the manufacturer no longer exists, such as Vekoma International B.V. and Vekoma Manufacturing B.V. In doing so, Vekoma Rides Parts & Services B.V. and Vekoma Rides Manufacturing B.V., including affiliated companies, agents and employees make no warranties and assume no responsibility for any misapplication or misinterpretation of the information provided, ride down time, consequential damages, injuries, causes of action, claims, demands and expenses (including legal fees), of any kind or nature, arising directly or indirectly, in whole or in part, from or out of this notification or associated with amusement ride equipment built by manufacturers other than Vekoma Rides Manufacturing B.V.



Issuing Entity:

Vekoma Rides Parts & Services B.V.
Schaapweg 18
6063 BA VLODRUP
The Netherlands

Bulletin No.: 1-SB-003-011106

Release Date:

Effective Date: Immediately

Supersedes: N.A.

Completion Date: N.A.

Details of issue continued:

Table of Contents:

Table of Contents:	3
1.1 General information	4
1.2 Disassembly and assembly instructions	4
1.2.1 General instructions regarding disassembly and assembly	4
1.3 Build in procedure steel rod	5
1.4 Attachment: WPS	10

Vekoma Rides Parts & Services B.V. issues notifications for the benefit of owners of amusement rides manufactured by Vekoma Rides Manufacturing B.V. as a service to the industry, and in the interest of employee and public safety. Vekoma Rides Parts & Services B.V. also issue notifications for the benefit of owners of amusement ride equipment for which the manufacturer no longer exists, such as Vekoma International B.V. and Vekoma Manufacturing B.V. In doing so, Vekoma Rides Parts & Services B.V. and Vekoma Rides Manufacturing B.V., including affiliated companies, agents and employees make no warranties and assume no responsibility for any misapplication or misinterpretation of the information provided, ride down time, consequential damages injuries, causes of action, claims, demands and expenses (including legal fees), of any kind or nature, arising directly or indirectly, in whole or in part, from or out of this notification or associated with amusement ride equipment built by manufacturers other than Vekoma Rides Manufacturing B.V.

Details of issue continued:

1.1 General information

In this service bulletin you will find the maintenance and mounting instructions for securing the brake shoes of the suspended brakes by using a steel rod and pipe. (Round 16 mm, length 80 mm and a pipe round 21.3 mm, length 45 mm. In total 4 sets of steel rod and pipe must be installed. See also picture 1: Brake after modification).

1.2 Disassembly and assembly instructions

1.2.1 General instructions regarding disassembly and assembly



Maintenance and repairs to the attraction may only be done by authorised and qualified persons, who have been instructed and trained for this purpose.

- Self-locking nuts, lock washers, split pins, retaining rings, etc. may only be used once.
- For any maintenance action, always use the correct tools.

▼ **During maintenance activities on the attraction, the following precautions must be taken:**

- Remove all keys from the operator control console.
- Press the Emergency stop button on the operator control console.
- Switch off all work switches or the main switches, and lock them with padlocks.
- Place a sign on the operator control console that shows that the attraction is under maintenance.
- Close entrance and exit, so no unauthorized persons or visitors can enter the attraction.
- Only use clean lubricated bolts and nuts.
- Do not lubricate self-locking nuts.

Details of issue continued:

1.3 Build in procedure steel rod

In order to build in the steel rod, follow the next procedures.

Vekoma Rides Parts & Services B.V. recommends to build out the complete brake and carry out the modifications in a workshop. Therefore remove the bolts, washers and nuts (figure 2/11).

▼ **Perform the following actions to disassemble the brake shoe:**

- 1 Make sure the pressure of the pneumatic system is off.
- 2 Loosen the pneumatic couplings (figure 1/1).
- 3 Remove the washers and nuts (figure 2/2, 3).

It may be helpful when the leaf is secured (with for example a glueing clamp).

- 4 Remove the bolt, washers and nuts (figure 2/4, 5, and 6)
- 5 Remove the brake shoe supports (figure 2/7).

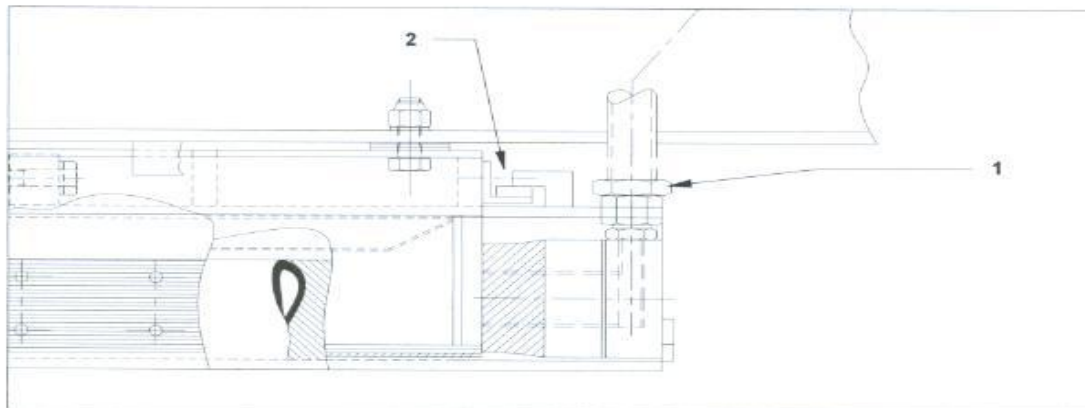

figure 1: Pneumatic coupling of brake

Details of issue continued:

- 6 Remove the attachment bolts for the leaf springs (figure 2/8).
- 7 Remove the brake shoe security bolt connections (figure 1/2).
- 8 Lift and turn the brake shoes (figure 2/9) and take them out of the brake frame (figure 2/10).
- 9 Take out the wind jammer (figure 2/1).

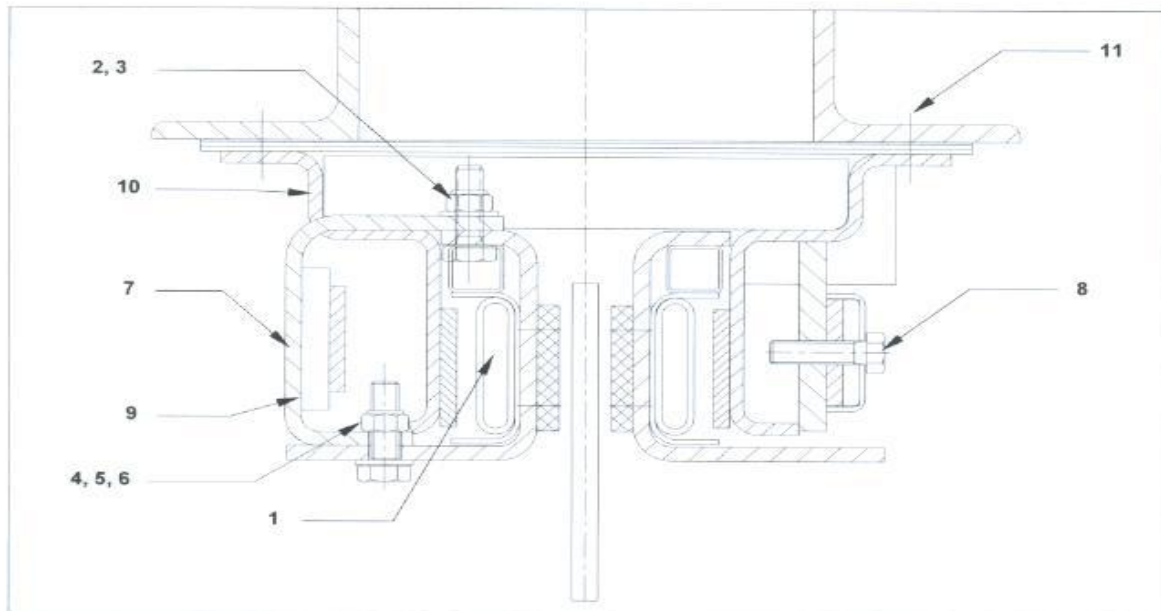

figure 2: Cross section of brake before mounting the steel rod



Issuing Entity:

Vekoma Rides Parts & Services B.V.
Schaapweg 18
6063 BA VLODROP
The Netherlands

Bulletin No.: 1-SB-003-011106

Release Date:

Effective Date: Immediately

Supersedes: N.A.

Completion Date: N.A.

Details of issue continued:

▼ **Weld the steel rod to the base frame:**

Note:

Material of the steel rod, AISI304 (material number 1.4301)

- 1 Remove the paint at the places where the steel rod should be welded.
- 2 Place the pipe (figure 3/1) over the steel rod (figure 3/2) and weld the steel rod to the base frame according to figure 3 and the WPS (see Attachment: WPS).
- 3 After welding the steel rod, and repairing the paint, assemble the brake in reverse order of disassembly.

Vekoma Rides Parts & Services B.V. issues notifications for the benefit of owners of amusement rides manufactured by Vekoma Rides Manufacturing B.V. as a service to the industry, and in the interest of employee and public safety. Vekoma Rides Parts & Services B.V. also issue notifications for the benefit of owners of amusement ride equipment for which the manufacturer no longer exists, such as Vekoma International B.V. and Vekoma Manufacturing B.V. In doing so, Vekoma Rides Parts & Services B.V. and Vekoma Rides Manufacturing B.V., including affiliated companies, agents and employees make no warranties and assume no responsibility for any misapplication or misinterpretation of the information provided, ride down time, consequential damages injuries, causes of action, claims, demands and expenses (including legal fees), of any kind or nature, arising directly or indirectly, in whole or in part, from or out of this notification or associated with amusement ride equipment built by manufacturers other than Vekoma Rides Manufacturing B.V.

Details of issue continued:

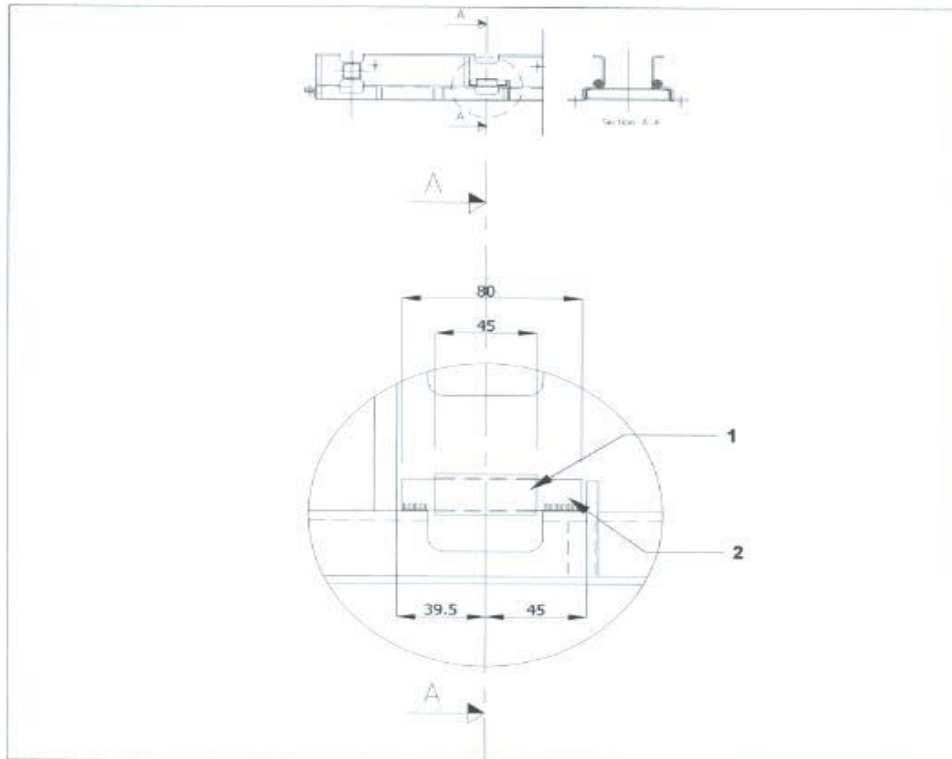

figure 3: Welding position of the plates to the brake shoe

Details of issue continued:

▼ **Perform the following steps to repair the paint:**

- 1 Grid blast the painted surfaces according to cleaning standard SA2,5 of ISO-8501-1 1988. If grid blasting is not possible, you must brush the surface according to cleaning standard SA2,5 of ISO-8501-1 1988.
- 2 Remove grease and dust from the surfaces.
- 3 Apply the first layer of paint.
- 4 Apply the finishing layer of paint.

Note:

It is not necessary to paint the pipe and the steel rod. (Stainless steel)

1.4 Attachment: WPS

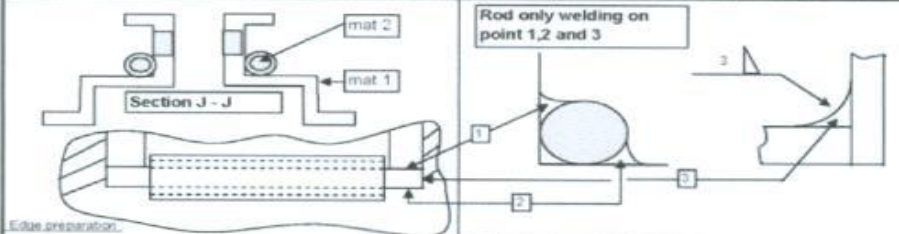
		Vekoma Rides Manufacturing B.V. Schaapweg 18 6063 BA Vlodrop Tel. (31) 475-409222		WPS : 01 Rev.nr: 0 Prep.by: L.Hoek PQR.nr: 34+35							
Welding Procedure Specification											
Ride /inst.	brakes general NDT - ASME			VALIDITY RANGE							
Subject:	pos 4B			See Code							
Specification:	Drawing: 20000 - 10 - 0141 rev B										
Vekoma order:	several	Base Materials		Material thickness mm							
Customer:	several	Base mat 1 S235JRO2		Several							
Sub.ordernr:		Base mat 2 (Rot) 304 RvS									
Tackweld:	Process Control	Weld Process		Preheat Details							
Tackweld proc:	SMAW	SMAW		Preheat temp: 20°C							
Preheat tackw:	20°	PA / PB (1F/2F)		Max interpass: 250°C							
Tackweld cont:	tempesticks/ crayons			Method: Propane / burners Control: Tempesticks / digital temp.							
											
Remarks: ALL CONSUMABLES ARE LOW HYDROGEN CONTROLLED < 5 ml/100 gr Before welding over previously metal, all slag be removed and the weld and adjacent base metal shall be brushed											
weld nr	weld proces	filler metal	aws code	size mm	gas flux	DC AC	Ampere min max	Volt min max	H.T. kJ/mm min max	Gas L/min	speed mm/sec
fill	SMAW	Arosta 309S	E 309L-16	2.5	na	DC +	70 - 90	21 - 23	0.5 - 1.0	na	2.0 - 3.0
a-3	SMAW	Arosta 309S	E 309L-16	2.5	na	DC +	70 - 90	21 - 23	0.5 - 1.0	na	2.0 - 3.0
Treatment of root: na						Prep: weldedges mechanical cutting and grinding					
inspection: %		Prep weld joint		Gouging with air		Gas Composition				Welders Qualif.	
Visual	100	Groove	filled joint	Size	na					DNV AWS	
MPI	na	Edge's prep	na	Amp	na					EN 287	
UT	na	Backing mat	na	Depth	na					LRS	
date: 28-7-06 name: L.Hoek			Customer: _____ date: _____ name: _____			Authority: _____ date: _____ name: _____					

Details of issue continued:



picture 1: Brake after modification



Issuing Entity:

Vekoma Rides Parts & Services B.V.
Schaapweg 18
6063 BA VLODROP
The Netherlands

Bulletin No.: 1-SB-003-011106

Release Date:

Effective Date: Immediately

Supersedes: N.A.

Completion Date: N.A.

Details of issue continued:



For additional information contact the Vekoma Rides Parts & Services B.V.:

P.O. Box 8006, 6060 AA Posterholt
Schaapweg 18, 6063 BA Vlodrop,
The Netherlands

Tel: +31 (0) 475-409222 (office hours)
Tel: +31 (0) 6-10917506 (outside office hours)
Fax: +31 (0) 475-403415

Email: service@vekoma.com

Copyright © 2006

Vekoma Rides Parts & Services B.V. issues notifications for the benefit of owners of amusement rides manufactured by Vekoma Rides Manufacturing B.V. as a service to the industry, and in the interest of employee and public safety. Vekoma Rides Parts & Services B.V. also issue notifications for the benefit of owners of amusement ride equipment for which the manufacturer no longer exists, such as Vekoma International B.V. and Vekoma Manufacturing B.V. In doing so, Vekoma Rides Parts & Services B.V. and Vekoma Rides Manufacturing B.V., including affiliated companies, agents and employees make no warranties and assume no responsibility for any misapplication or misinterpretation of the information provided, ride down time, consequential damages injuries, causes of action, claims, demands and expenses (including legal fees), of any kind or nature, arising directly or indirectly, in whole or in part, from or out of this notification or associated with amusement ride equipment built by manufacturers other than Vekoma Rides Manufacturing B.V.